

Commercial Applications

BKP 250-AC

Advanced Heat Pipe Dehumidifier

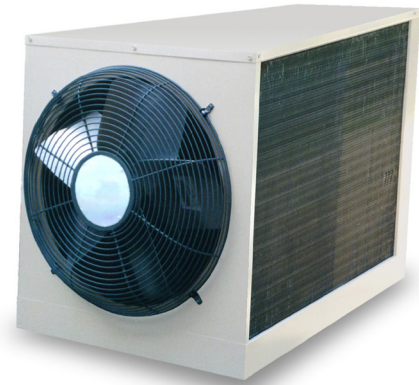

with
Remote Condenser

Standard Features

- * Dehumidifier heat pipe enhancement
- * Heavy duty painted sheet metal cabinet
- * Long life Copeland® scroll compressor
- * Time delay relay for compressor protection
- * Freeze protection
- * Remote dehumidistat control
- * Built-in filter dryer
- * Easy access for servicing
- * Squirrel cage high static/low noise blower
- * Duct flanges

Optional Feature

- * Condensate pump package



**Heat Pipe
Technology, Inc.**

“A World of Difference.”

Performance Table - BKP 250-AC

Inlet Air Temp	POUNDS PER DAY	Inlet Relative Humidity						
		40%	50%	60%	70%	80%	90%	100%
55°F		•••	•••	•••	•••	•••	•••	175
60°F		•••	•••	•••	138	175	205	225
65°F		•••	105	145	178	225	250	280
70°F		75	135	183	218	265	300	328
75°F		105	165	218	258	300	338	•••
80°F		138	195	250	295	•••	•••	•••
85°F		165	213	275	•••	•••	•••	•••
90°F		188	•••	•••	•••	•••	•••	•••

••• Contact factory.

 double box) indicates standard A.H.A.M. rating conditions.

Performance data may vary with conditions at each installation and is provided only as a guide for selecting the correct dehumidifier.

Specifications

Model BKP 250-AC	Indoor	Outdoor
Dimensions (WxHxD) (in.)	45 x 22 x 22	24 x 25 x 20
Net Weight (lbs)	200	65
Air Flow (CFM)	600	800
Refrigerant	R-22	R-22
Condensate Pump	Optional	
Drain Connection Size	3/4" NPT	
Heat Added to Space ¹ (Btu/hr)	8,500	
Sensible Capacity ² (Btu/hr) at 80°F/60%RH	10,000	
Blower (Dia.x w) or Fan Size (in.)	9 x 7	14
Ext. Static Pressure (in. WG)	0.3	
Air Outlet (WxH) (in.)	9 3/8 x 10 3/8	
Air Inlet (WxH) (in.)	18 x 18	
Filter (in.)	16 x 20 x 2	
Vapor Line Size (in.)		1/2
Liquid Line Size (in.)		3/8
Max. Length (ft)		50
Electrical		
Power 60 Hz	208-230V / 1ph	208-230V / 1ph
Compressor RLA (Amp)	13.6	
Compressor LRA (Amp)	61	
Blower or Fan Motor (HP)	1/4	1/4
Max. Fuse or HACR Circuit Breaker (Amp)	30	
Min. Circuit Ampacity (Amp)	19	2
Full Load Power Consumption (kW)	2.8	0.35
Normal Operating Power Consumption (kW)	2.5	0.3

* Shipped separate for installation by contractor.

¹ Use as dehumidifier.

² Use as A/C dehumidifier with remote condenser. Latent Capacity from table above.
We reserve the right to make product improvements.

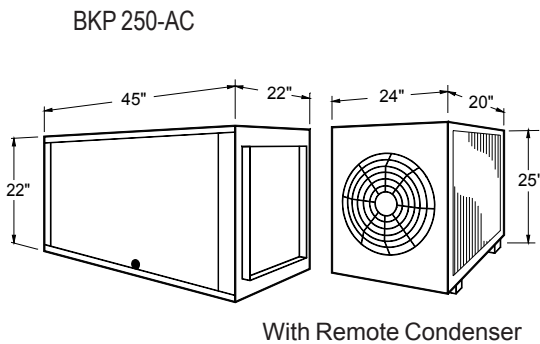

HP Heat Pipe
Technology, Inc.

4340 NE 49th Ave., Gainesville, Florida 32609

Toll Free: 1-800-393-3464 ❖ Tel. (352) 367-0999 ❖ Fax: (352) 367-1688

Email: heatpipe@heatpipe.com ❖ www.heatpipe.com